



# PCX™ 260

## Digital Audio Matrix Processor

### Operating Manual



Model Number or Name:

Date of Purchase:

Serial Number:

Dealer Name:



### FCC/ICES Compliancy Statement

This device complies with Part 15 of the FCC rules and Industry Canada license-exempt RSS Standard(s). Operation is subject to the following two conditions: (1) this device may not cause harmful interference, and (2) this device must accept any interference received, that may cause undesired operation.

Le présent appareil est conforme aux CNR d'Industrie Canada applicables aux appareils radio exempts de licence. L'exploitation est autorisée aux deux conditions suivantes: (1) l'appareil ne doit pas produire de brouillage, et (2) l'utilisateur de l'appareil doit accepter tout brouillage radioélectrique subi, même si le brouillage est susceptible d'en compromettre le fonctionnement.

**Warning:** Changes or modifications to the equipment not approved by Peavey Electronics Corporation can void the user's authority to use the equipment.

**Note** – This equipment has been tested and found to comply with the limits for a Class B digital device, pursuant to Part 15 of the FCC Rules. These limits are designed to provide reasonable protection against harmful interference in a residential installation. This equipment generates, uses, and can radiate radio frequency energy and, if not installed and used in accordance with the instructions, may cause harmful interference to radio communications. However, there is no guarantee that interference will not occur in a particular installation. If this equipment does cause harmful interference to radio or television reception, which can be determined by turning the equipment off and on, the user is encouraged to try and correct the interference by one or more of the following measures.

- Reorient or relocate the receiving antenna.
- Increase the separation between the equipment and receiver.
- Connect the equipment into an outlet on a circuit different from that to which the receiver is connected.
- Consult the dealer or an experienced radio/TV technician for help.

#### **Caution**

The equipment complies with FCC radiation exposure limits set forth for an uncontrolled environment.

## Crest Audio® PCX™ 260

The Crest Audio PCX 260 is a two input - six output digital matrix speaker management processor boasting 96 kHz sample rate processing with an exceptionally quiet and accurate AD/DA interfaces and filter response. Either of the 2 input channels, balanced line XLR's, can be routed to any/or all of the 6 output channels, being fully adjustable on either input or output via the digital matrix system, for any speaker management cabinet configuration. The units software and advanced DSP algorithms offer professional audio grade signal processing and control features to manage, optimize and protect FoH, monitor and multi-zone speaker systems while ensuring exceptional audio signal clarity and integrity without loss or coloration.

Input features include Gain, Mute, HP / LP filters, 8-band PEQ, Polarity and up to 680 ms of Delay. Each output features an additional 9-band PEQ, Gain, Compressor / Limiter, Polarity, up to 680 ms of Delay, and Mute. Crossover & Band-pass filters can be selected between Butterworth, Bessel or Linkwitz-Riley with alignments from 1<sup>st</sup> order (6 dB/Oct) to 8<sup>th</sup> order (48 dB/Oct). EQ filter types include PEQ, Low-Shelf, Hi-Shelf, Low-Pass, High-Pass, All-Pass1 and All-Pass2. An internal signal generator provides Sine, White Noise and Pink Noise.

The front panel of the PCX 260 offers quick and simple local configuration and control via a front panel LCD display, rotary encoder and dedicated function buttons. Alternatively an Ethernet port, located at the back panel, allows for higher resolution graphical user interface configuration and control from a PC utilizing the Crest Audio PCX Editor Software that also allows configuration files to be saved and loaded from the user's PC.

Please read this operating manual carefully to ensure your personal safety as well as the safety of your equipment.

### Features

- 2 balanced XLR inputs & 6 balanced XLR outputs
- Sample rate: 96 kHz
- A/D & D/A Converters: 24-bit Delta-Sigma
- Setup & Control via Ethernet or USB-B
- Serial control via RS-232 / RS-485
- 5-segment LED meters on each input and output
- Input: Gain, Mute, HP & LP filters, 8-band PEQ, Polarity, Delay
- Output: 9-band PEQ, Gain, Compressor / Limiter, Polarity, Delay, Mute, Crossover / Band-pass filters
- Signal generator: Sine, White Noise, Pink Noise
- EQ filter types: PEQ, Low-Shelf, Hi-Shelf, LP, HP, All-Pass1 & All-Pass2
- Crossover / Band-pass filters: Butterworth, Bessel & Linkwitz-Riley from 1<sup>st</sup> to 8<sup>th</sup> order
- Security lock
- PCX Editor software for PC allows complete remote setup and operation via Ethernet or USB

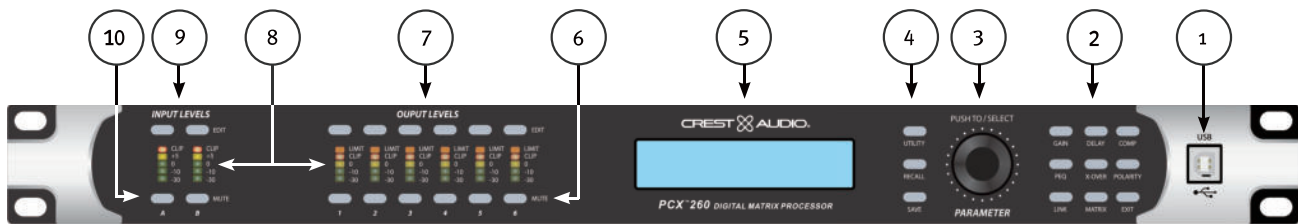

### (1) USB port

This USB "B" connector is used to connect a host computer for editing, and control using the PCX Editor Software.

### (2) Parameter Function Buttons

The function buttons allow direct access to all editing and navigating functions. Illuminated buttons indicate the selection of a function. Editable parameters / functions do vary when in input, output, or system mode (no input or output selected).

**GAIN:** Gives access to channel Gain controls

**DELAY:** Gives access to channel Delay controls

**COM:** Available only for output editing, gives access to channel Compressor / Limiter controls

**PEQ:** Gives access to channel PEQ controls

**X-OVER:** Gives access to the Low-Pass filter and High-Pass filter controls

**POLARITY:** Gives access to channel Polarity controls

**MATRIX:** Available only for output editing, gives access to the routing of inputs to outputs

**EXIT:** Exit channel editing

### (3) Parameter Encoder Knob

The parameter encoder knob is used to scroll through parameters, by pressing the encoder the selected parameter can be edited.

### (4) System Function Buttons

**UTILITY:** Utility functions include setting the Unit ID, network IP address, Security Lock, Input Signal, Signal Generator, Copy channels and setting Delay units

**RECALL:** Load system presets

**SAVE:** Save system presets

**(5) LCD Display**

Used in conjunction with the front panel controls to edit processing parameters.

**(6) Output Mute Buttons**

Pressing the mute button mutes or unmutes the corresponding output. The selected button illuminates red when muted.

**(7) Output Edit Buttons**

Press one of these buttons to begin the editing process for the selected output. The required editing function can be selected by the parameter function buttons on the right side of the unit (2).

**(8) Input & Output Monitoring**

**Input:** Two 5-segment LED meters, one for each input, indicate the input signal level with the top Clip LED illuminating before the onset of clipping. Although you will want to avoid clipping, you will achieve best performance if the "0 dB" LED lights frequently during loud passages.

LED Meters Inputs			
LED Colour	Label	dBu*	dBFS*
Red	Clip	+15	-5
Yellow	+5	+5	-15
Green	0	0	-20
Green	-10	-10	-30
Green	-30	-30	-50

**Output:** Six 5-segment LED meters, one for each output, indicate the output signal level. The top LED illuminates to indicate the signal has reached the threshold set in the compressor/limiter and that gain reduction is occurring. The bottom 4 LEDs indicate the output signal level. The Clip LED illuminates before the onset of clipping. Although you will want to avoid clipping, you will achieve best performance if the "0 dB" LED flashes frequently during loud passages.

LED Meters Outputs			
LED Colour	Label	dBu*	dBFS*
Amber	Limit	-	-
Red	Clip	+15	-5
Yellow	0	0	-20
Green	-10	-10	-30
Green	-30	-30	-50

**(9) Input Edit Buttons**

Press one of these buttons to begin the editing process for the selected input. The required editing function can be selected by the parameter function buttons on the right side of the unit (2).

**(10) Input Mute Buttons**

Pressing the mute button mutes or unmutes the corresponding input. The selected button illuminates red when muted.

\* 0 dBFS = Maximum signal level before clipping (Full Scale)

\* 0 dBu = 0.775 V rms

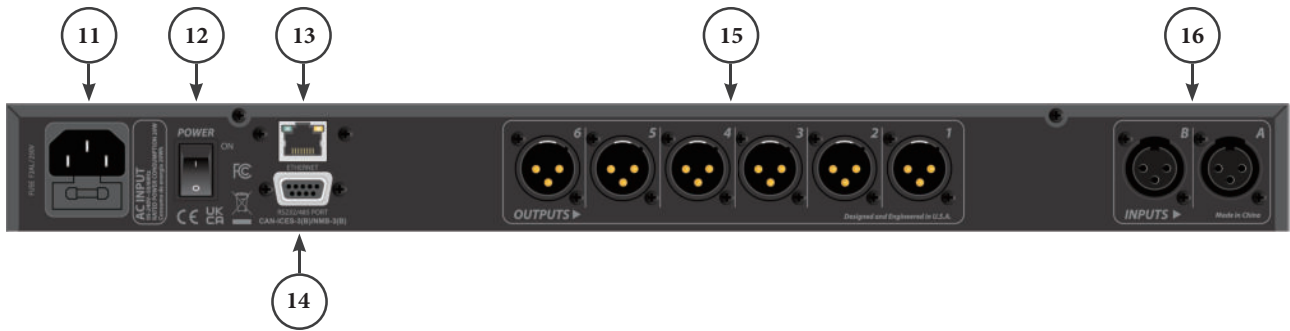

### (11) IEC Power Cord Connection and Fuse Holder

This receptacle is for the IEC line cord (supplied) that provides AC power to the unit. It is very important that you ensure the unit has the proper AC line voltage supplied.

Please read this guide carefully to ensure your personal safety as well as the safety of your equipment. Never break off the ground pin on any equipment. It is provided for your safety. If the outlet used does not have a ground pin, a suitable grounding adapter should be used and the third wire should be grounded properly. To prevent the risk of shock or fire hazard, always be sure that the unit and all other associated equipment are properly grounded.

**⚠ Caution:** For 95 to 240 VAC operation, a “F2AL 250V” fuse rated at 2 amps should be used.

### (12) Power Switch

This rocker switch supplies AC power to the unit when switched to the ON position. The ON position is with the top side of the switch pushed in or nearly flush with the rear panel.

### (13) Ethernet Control Interface

Ethernet port for control of the PCX using the graphical user interface.

### (14) D-sub 9 Connector

Connection for RS-232 and RS-485 serial control.

### (15) Outputs

XLR balanced outputs 1 - 6.

### (16) Inputs

XLR balanced inputs A and B.

Operating the PCX processor from the front panel is made simple by a wide array of buttons and a simple intuitive interface.

### Start Screen



The start screen shows product name and firmware version.



After a short moment the currently active preset is displayed.

### Global Functions: Utility, Recall & Save



Pressing the [UTILITY] button will open the screen for system settings. Each press of the [UTILITY] button will lead on to the next screen in the sequence. You can press the [EXIT] button at any time to return to the main screen.

### UTILITY: Device ID

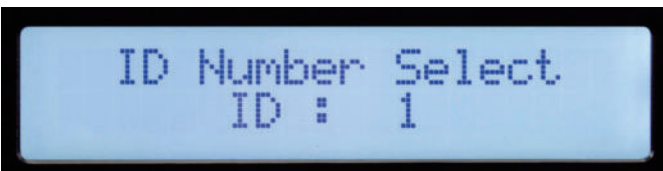

The ID number of the unit can be set in this screen. The ID is used with the Editor software to identify this unit when multiple units are connected. Each unit must have a unique identifier. It is most important when units are connected together using the RS-485 serial interface. See the section on serial communication for more details. The initial ID is set to [1]

## UTILITY: Ethernet Address



The Ethernet IP address of the unit can be set in this screen. The initial IP address is set to [192.168.1.101] Make sure to note the new address if you edit it!

## UTILITY: Security Lock

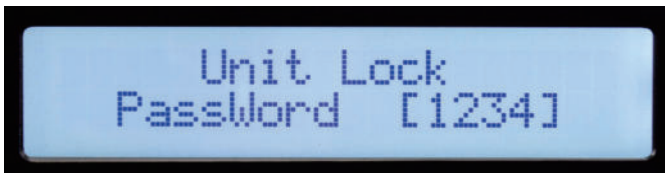

On this screen you can set a four-character security password. Any combination of letters and numbers can be set. Press the encoder and rotate to change each digit. After the last digit you can activate the security lock with [Y] or turn it off with [N]. The initial password is set to [1234].

## UTILITY: Input Source Select



Select [ANALOG INPUT] for normal operation, this selection will route the analog inputs on the rear of the PCX to the outputs. The unit also offers an internal signal generator that can be used for setup and testing. Rotating the parameter knob allows you to select either [PINK NOISE], [WHITE NOISE] or a [SINE-WAVE] between 20 Hz to 20 kHz as the source for all inputs. The new selection will blink on the screen. Press the Parameter knob to select. You can mute the outputs you do not wish to receive the signal from the generator.

## UTILITY: Copy



Settings can be copied from one input channel to another input or from one output to another.

## UTILITY: Delay Units



The units used to set delays can be selected on this screen. The options are milliseconds [ms], meters [m] or feet [ft].

## RECALL: Load Preset

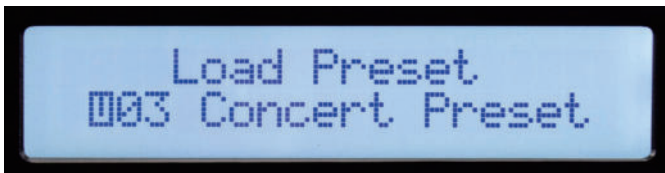

Select the desired user preset [U01] to [U30] by rotating the parameter knob then press the encoder to load the preset.

## SAVE: Store Preset

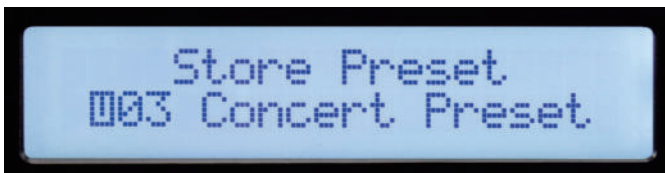

Select the desired user preset storage location [U01] to [U30] by rotating the parameter knob then press the encoder to confirm the selection. Enter a name for the preset and press the encoder again when the [Y] appears to complete the store process.

## Input &amp; Output Parameters



This section of controls allows adjustments to a particular input or output. Select the channel you wish to adjust by pressing the corresponding [EDIT] button, (9) for one of the inputs or (7) for one of the outputs. The corresponding parameter function buttons (2) that are available to edit will illuminate. The parameter function button selected will start blinking.

Editable parameters are:

**Input:** [GAIN], [PEQ], [LINK], [DELAY], [X-OVER] & [POLARITY]

**Output:** [GAIN], [PEQ], [LINK], [DELAY], [X-OVER], [MATRIX], [COMP] & [POLARITY]

While editing, you can select another function or another channel by pressing the appropriate button. Press [EXIT] to return to the main screen.

## GAIN

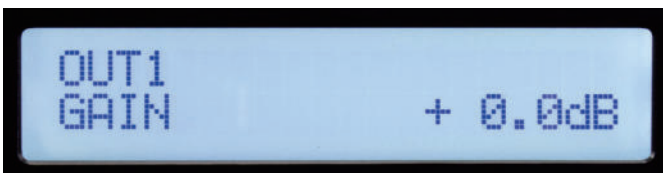

The input and output gain can be adjusted in a range of -60 dB to +12 dB in 0.1 dB increments. For best operation, the gain should not be set at extreme settings (0 dB is optimal). It is always best to adjust the signal level driving the PCX input so that the Yellow LED lights on louder signals. When using the crossover on an output, you may need to increase the gain to achieve sufficient signal level to drive the amplifier. If you find that you need to turn down an output very far below 0 dB, you will get quieter operation if you reduce the amplifier input level control instead.

## PEQ

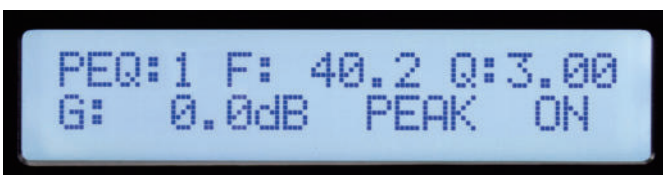

The input channels do have 8-band PEQ and the outputs 9-band. The EQ band is indicated in the upper left corner of the display. (Band 1 is shown above) The parameter selected for adjustment will blink on the screen. Press the parameter knob to select a parameter for editing. Rotate the knob to adjust. F=Frequency, Q=Bandwidth, G=Gain.

The EQ types available are: Peak/Dip (PEAK), Low-Shelf (L-SHLF), High-Shelf (H-SHLF), Low-Pass (L-PASS), High-Pass (H-PASS), All-Pass1 (A-PAS1), All-Pass2 (A-PAS2). "On" is active and "By"= Bypass.

## LINK

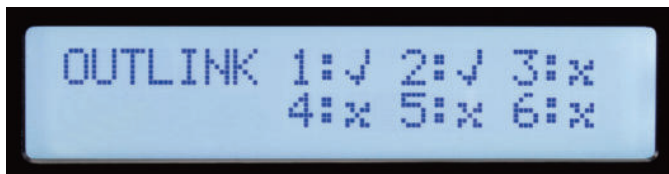

Many times, in particular for stereo signals, you may want to make the same adjust to two or more channels at the same time. Using the link function, inputs can be linked to other inputs and outputs can be linked to other outputs. The check marks on the above screen indicate linkage. When channels are linked, the edit buttons for those channels will blink simultaneously when editing.

## DELAY

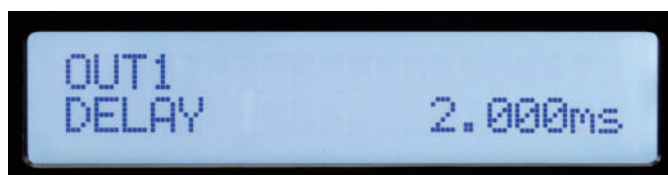

Up to 680 milliseconds of delay can be added to any input or output. The delay resolution is 1 sample or 10.4 microseconds. You can change the delay units in the [UTILITY] menu, available options are milliseconds [ms] range from 0 ms to 680 ms, meters [m] range from 0 m to 234 m or feet [ft] range from 0 ft to 766 ft.

## X-OVER



Although the button is labeled [X-OVER] and that is how these functions are often used, each input and output do have very flexible High-Pass and Low-Pass filters, each ranging from 20 Hz to 20 kHz, that can be configured for a wide variety of applications.

To activate the filter use the parameter control to select [BYPASS] on the screen and change it to the desired filter type. There are 3 filter types available, Butterworth [BUTTER], Bessel [BESSEL], and Linkwitz-Riley [LINK/R]. Selecting [BYPASS] will switch the filters off. Filter slopes of 6 dB/Octave (1<sup>st</sup> order) to 48 dB/Octave (8<sup>th</sup> order) can be selected. You can adjust cut-off frequency, slope, and filter type.

## MATRIX



The Matrix screen is only available when editing an output. This is where the inputs that drive each output are connected. Each output channel can be assigned to one input channel or a mix of input channels. The above screen shows input "A" as the signal source for output 1. If multiple inputs are selected, their signals are summed.

## COMP (Compressor)



The compressor screen is only available when editing an output.

The compressor parameters are:

T = ThThreshold (-90 dB to +20 dB)

R = Ratio (1 :1.0 to 1 :20.0 / LIMIT)

AT = Attack Time (1 ms to 999 ms)

RT = Release Time (1 ms to 999 ms)

The threshold is roughly equal to the limiting level in dBu. The limit LED corresponding to the output channel will illuminate when the threshold is exceeded. The status is also displayed in the software editor when connected to a PC.

## POLARITY

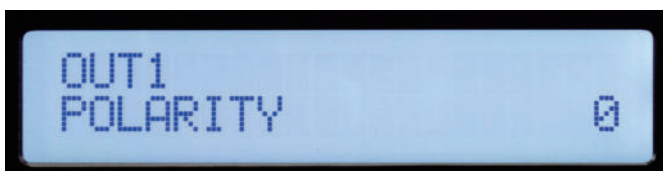

The Polarity screen is available when editing inputs and outputs. This parameter can be switched between 0 = Normal polarity and 180 = Reverse polarity.

## PC CONNECTION

### USB CONNECTION

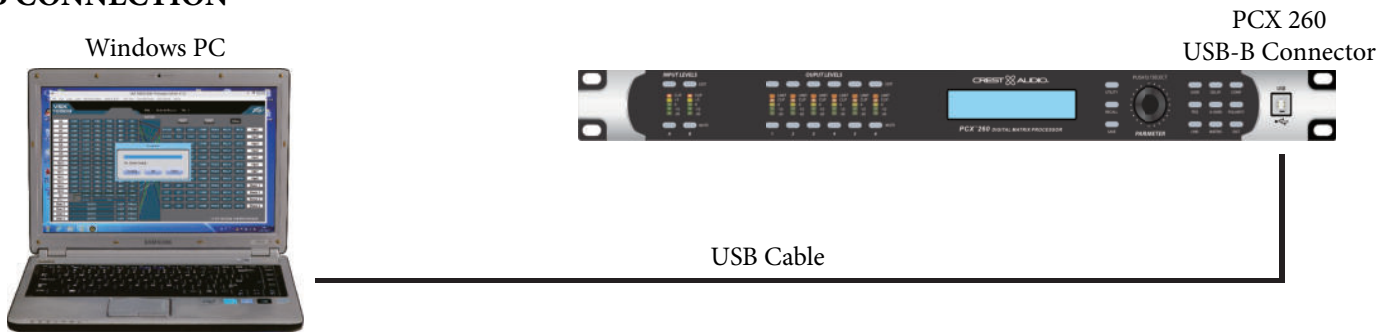

### ETHERNET CONNECTION - One Unit via LAN

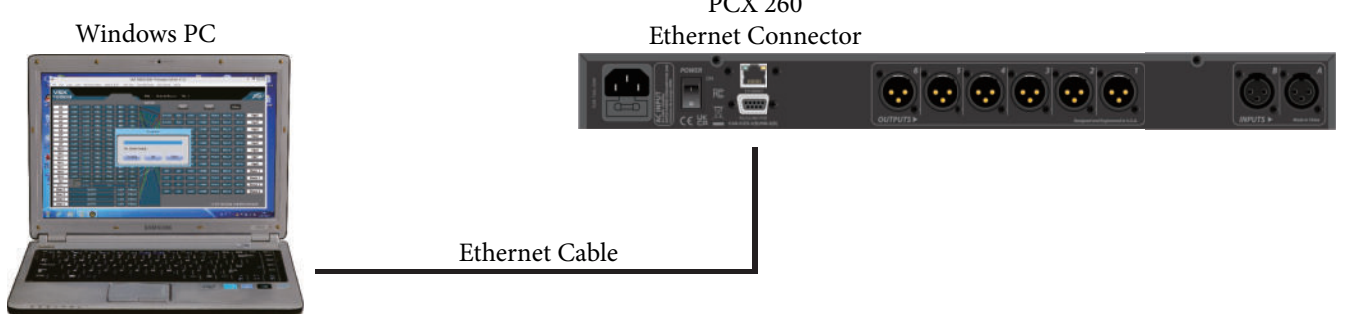

### ETHERNET CONNECTION - Multiple Units via LAN or WiFi

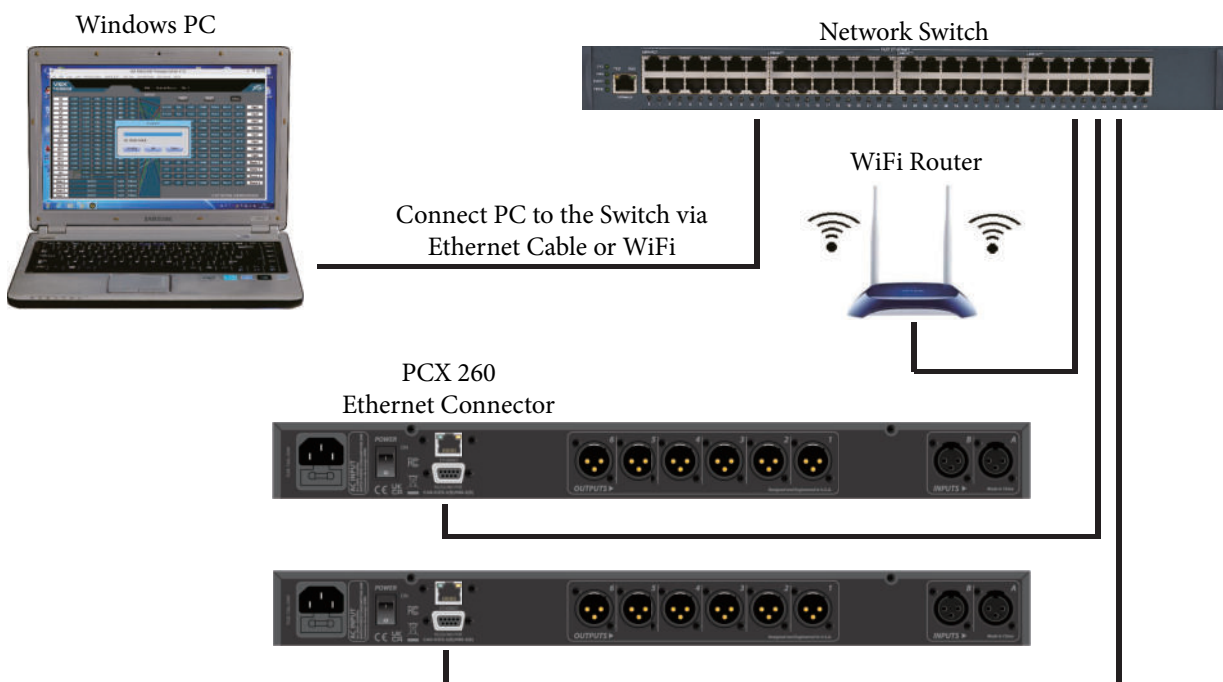

**ATTENTION:** When connecting via Ethernet or WiFi to a Windows PC, make sure to set the IP address correctly! All PCX processors use a "Static" IP address. How to set the IP address and ID of the unit is described in the utility section of the manual. The Editor must be set to a matching IP address and ID in order to connect.

## SOFTWARE INSTALLATION

1. Download the latest version of the PCX Editor Software for Windows from [www.peaveycommercialaudio.com](http://www.peaveycommercialaudio.com) and extract the zip file.

 Crest Audio PCX260 DSP Processor Editor Setup INT V1.01.zip

2. Start the software installation by double clicking the exe file

 PCX260 DSP Processor Editor Setup INT V1.01.exe

3. Follow the instructions on the screen until the software installation is finished. Do not launch the software at this point!

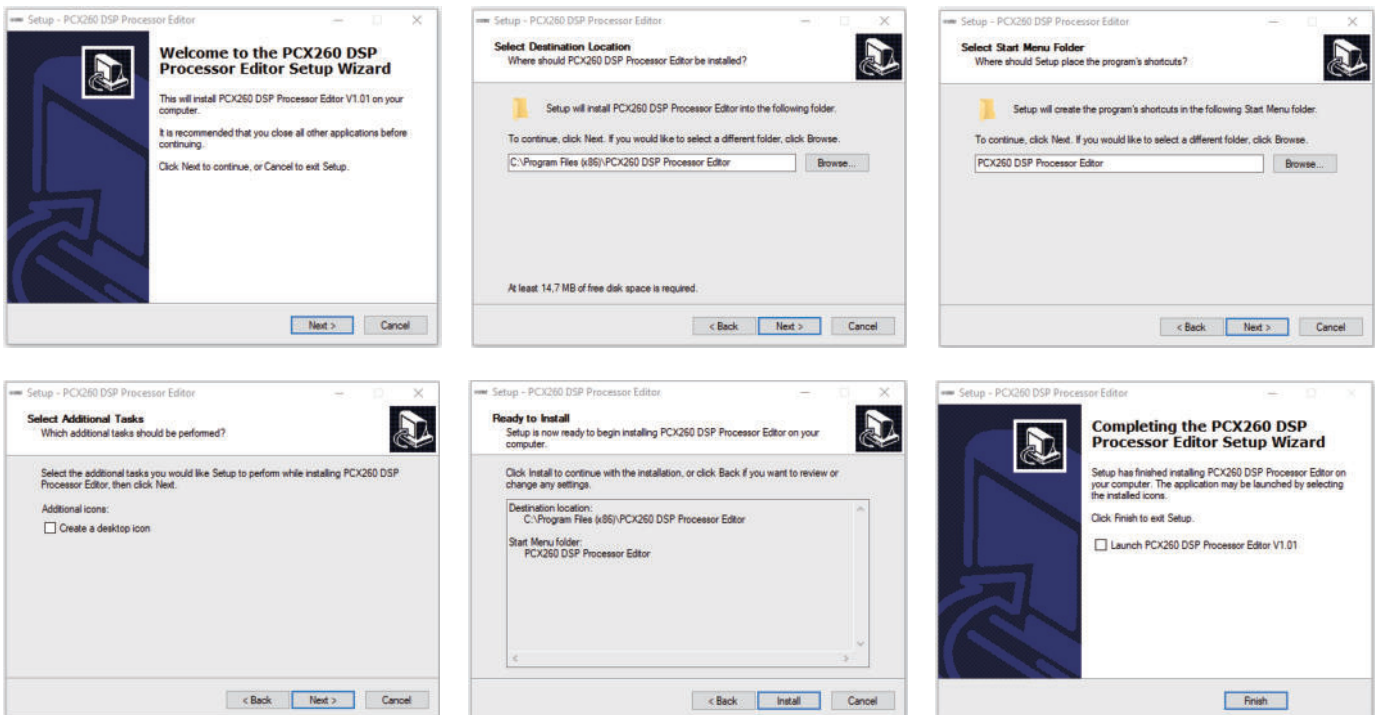

4. Connect your computer via a USB cable to the PCX 260 and turn the unit on. Your Windows operating system should now recognize the added USB device and install necessary drivers. You can also connect your computer via the Ethernet port or a network switch to the PCX 260.

5. Start the PCX 260 Editor Software. It automatically will recognize the connected device(s)

6. The [Offline] button on the top right screen will change from blue to green and state [Online]

7. When the unit is connected to the Editor Software, the front panel controls are disabled

## SOFTWARE INTRODUCTION

The PCX 260 can be setup and controlled using the PCX Editor software which runs on a Windows computer. To control the PCX, the computer can be connected to the unit via USB, Ethernet, RS-232 or RS-485. For most applications, USB or Ethernet will be the preferred solutions.

If the computer is connected before launching the PCX Editor software, the software will search for connected devices. If it does not connect, check the IP address and device ID settings of the unit do match the settings in the editor. Also, make sure the PCX IP address is set in the network range of your computer and router. You can then click scan or click the [Offline] icon in the upper right corner of the screen to scan again and connect.

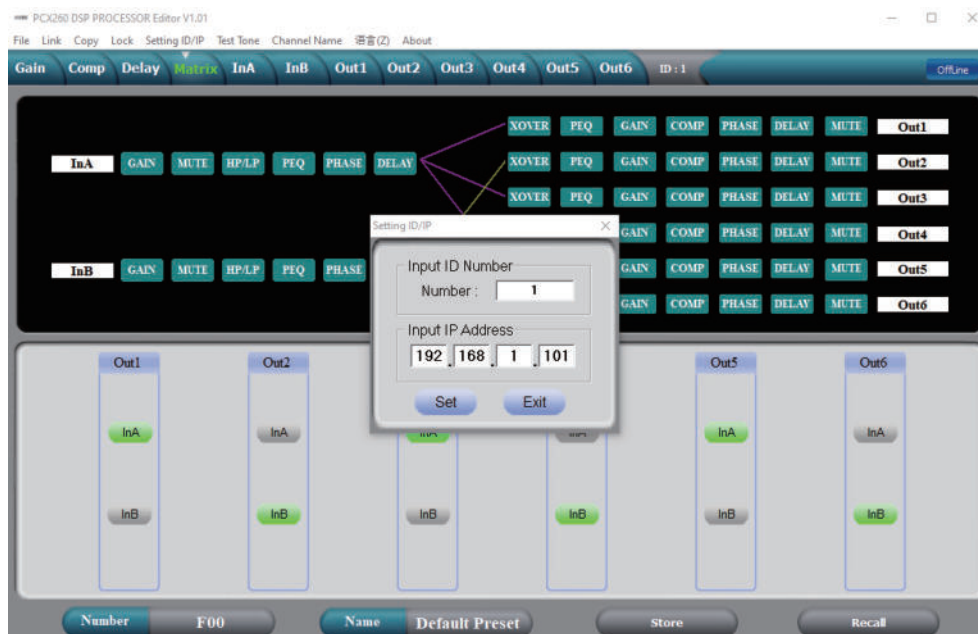

Once connected, the setting from the unit will be loaded and the icon will turn green to indicate the unit is now online. Use the tabs at the top of the screen to navigate to the desired screen.

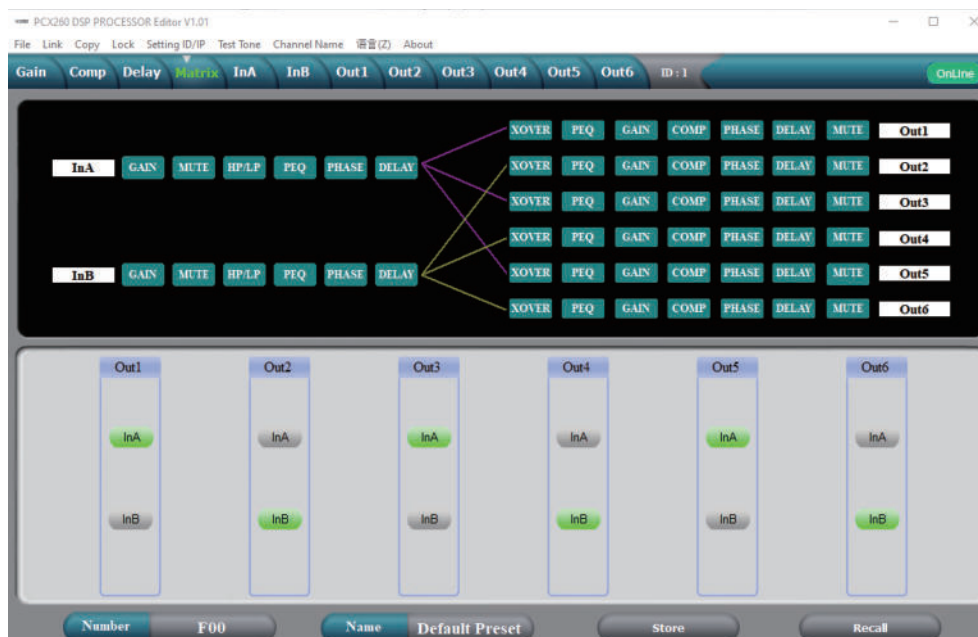

GAIN

You can access the Gain settings by clicking the Gain tab (1) or on the Matrix tab (3) you can select [GAIN] for the inputs (2) or outputs (4) separately.

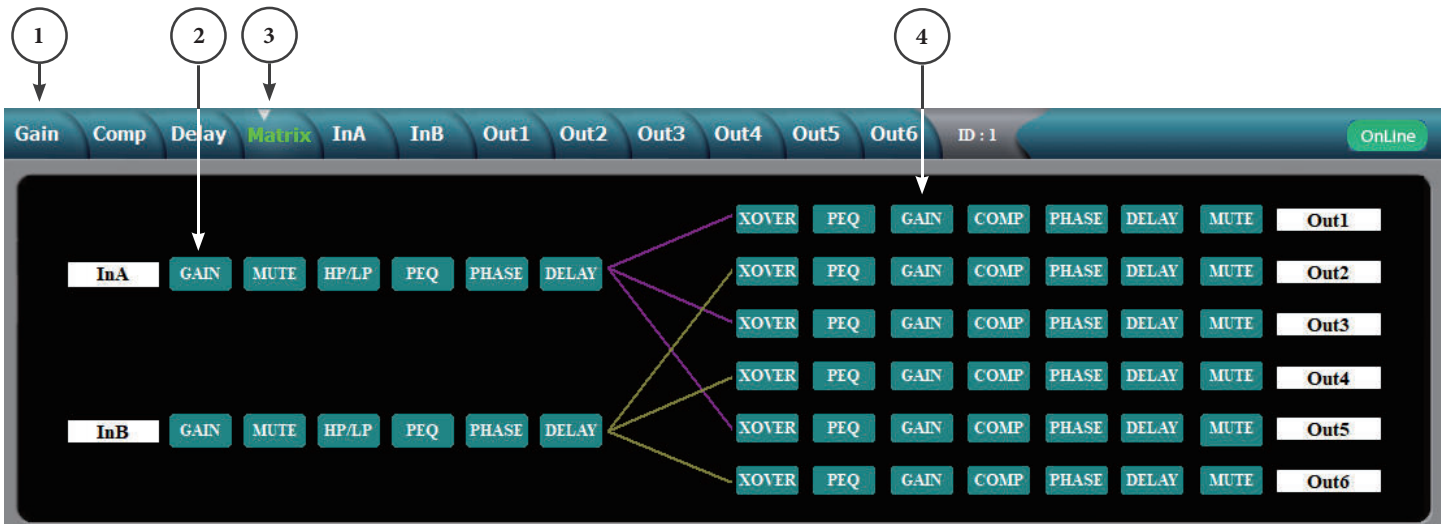

The Gain tab screen is split into two parts. The display area (top) and control area (bottom). Signal curves of inputs and outputs can be displayed by ticking the corresponding boxes on top of the display area.

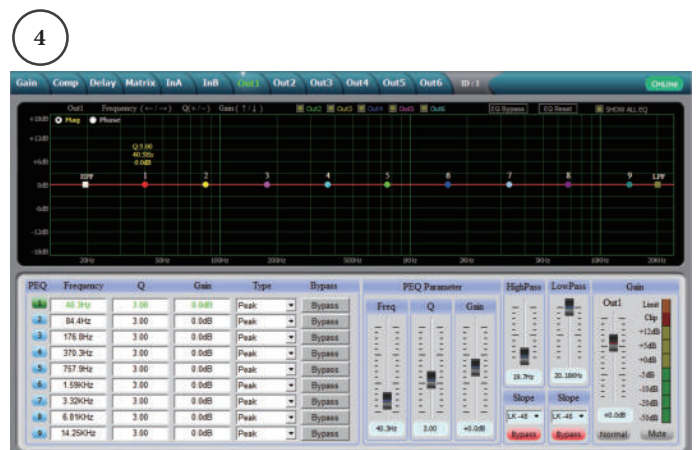

## COMPRESSOR

You can access the Compressor settings of all 6 output compressors by clicking the Comp tab (1) or on the Matrix tab (2) you can select [COMP] in the outputs section (3). This screen will also show signal level and limit status.

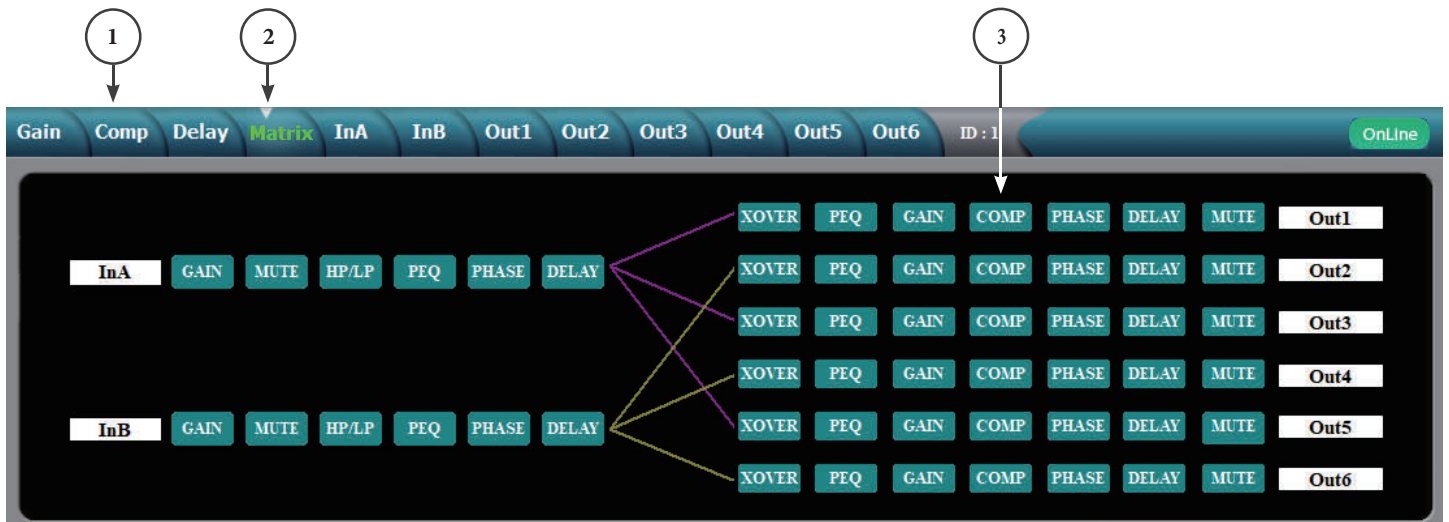

The screen below states the settings of the compressor for the selected output channel. Threshold, Ratio, Attack Time, and Release Time can be set for each output individually.

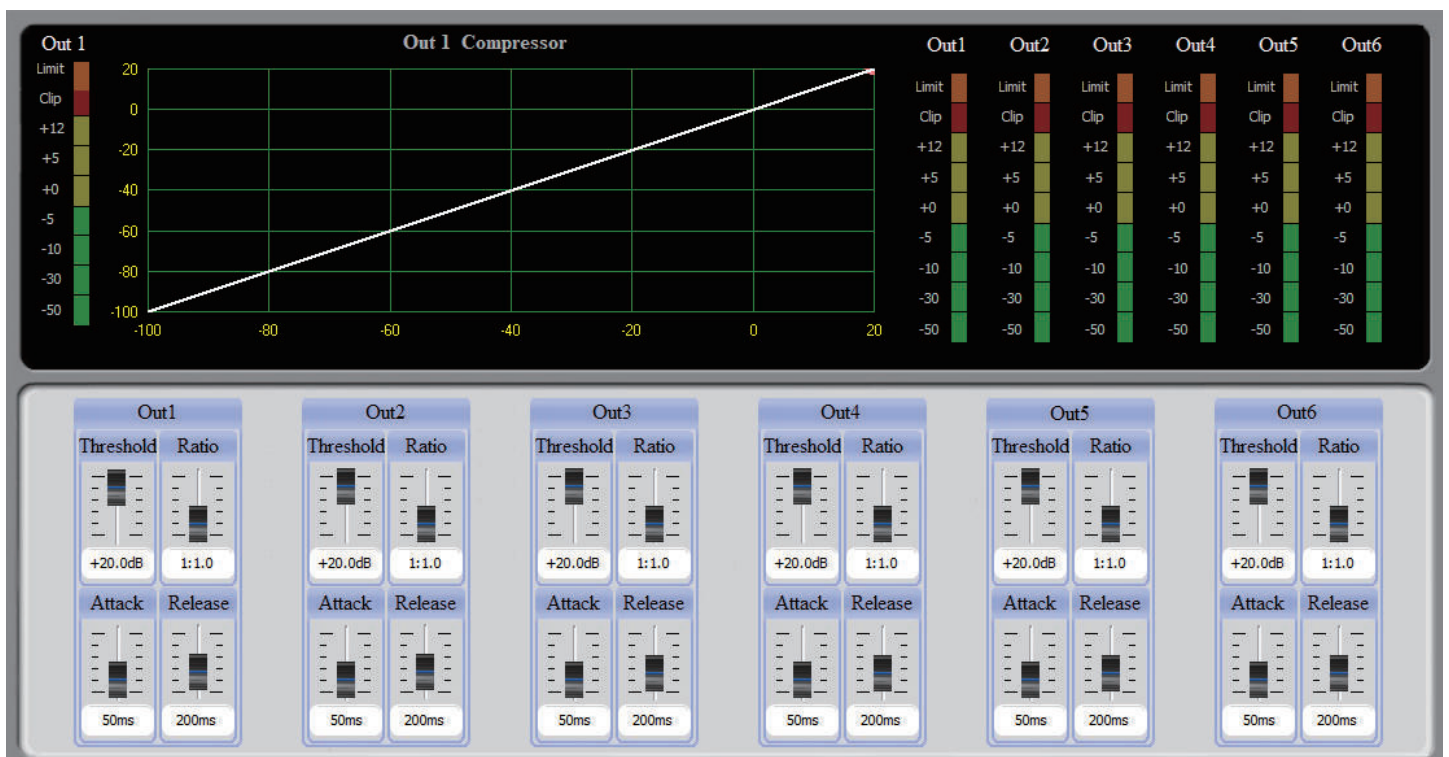

DELAY

You can access the Delay settings by clicking the Delay tab (1) or on the Matrix tab (2) you can select [DELAY] for the inputs (3) or outputs (4) separately.

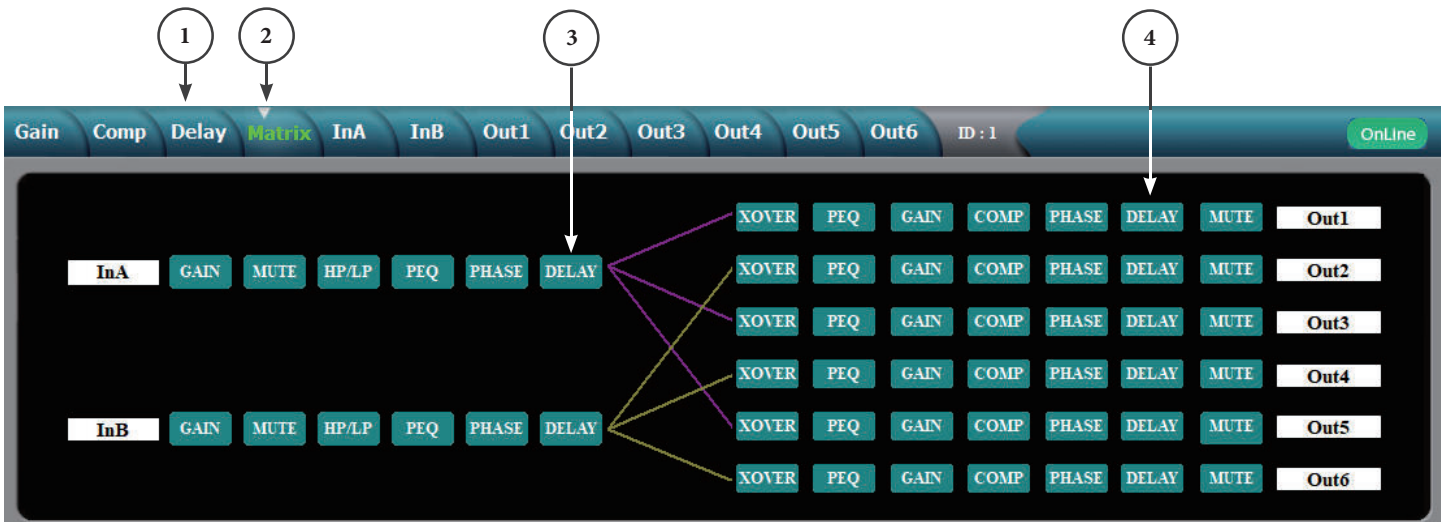

All of the input and output delays are shown in the below screen. Delays can be adjusted using the sliders at the bottom, by sliding the speakers at the top or by direct typed entry. To directly enter the delay time, double click the delay time and type a new value. If you hold down the left mouse button on a slider, you can fine adjust the delay by using the up and down arrow buttons on the keyboard. The delay display units can be selected on the right side.

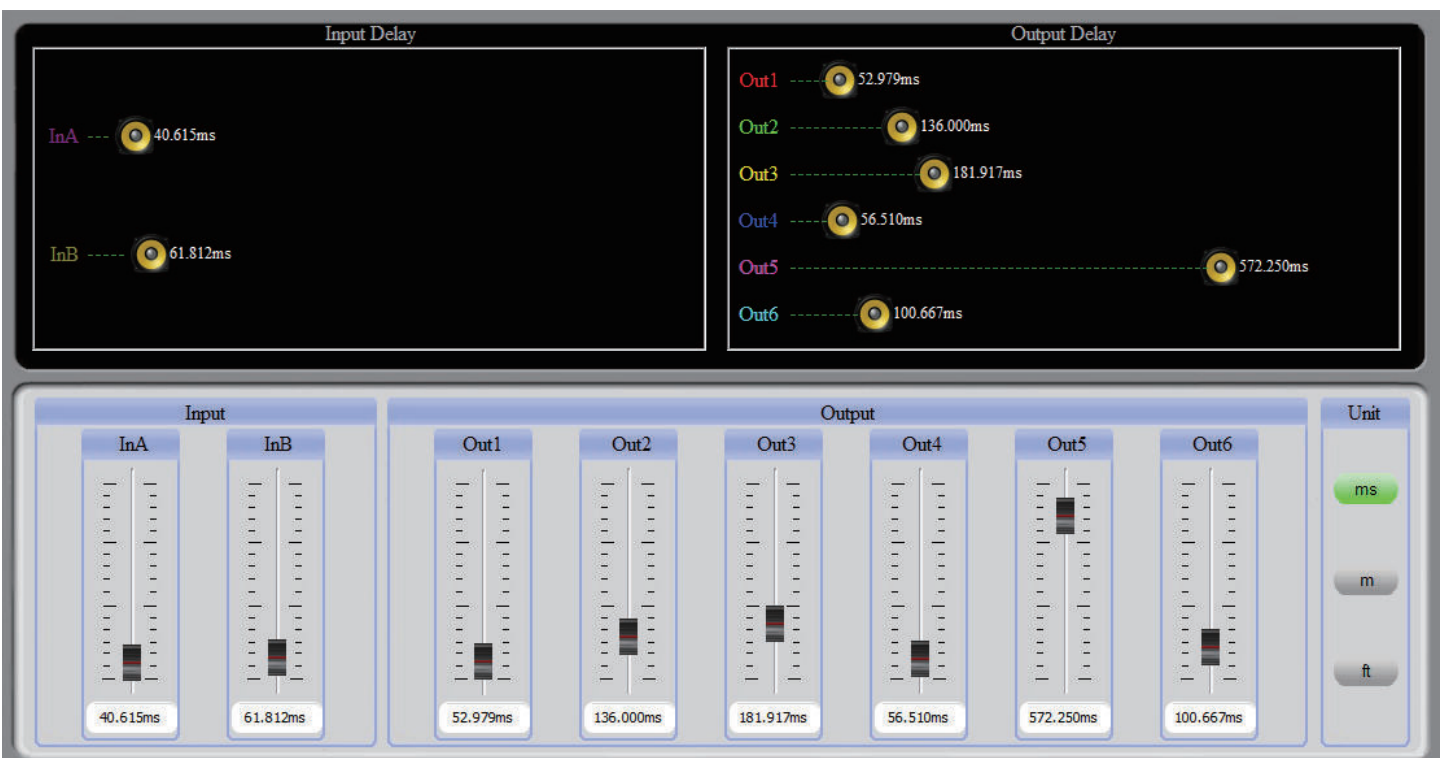

## MATRIX

The input sources for each output are routed on the Matrix screen. Click the corresponding input button below each output header, once selected the button will turn green. If more than one source is selected those inputs will sum. A graphical representation of the routing is displayed in the top screen. Inputs and outputs can also be labeled in the top screen by clicking on [InA], [InB], [Out1], [Out2], [Out3], [Out4], [Out5] or [Out6].

The screenshot displays the Matrix software interface. At the top, a navigation bar includes tabs for Gain, Comp, Delay, Matrix (selected), InA, InB, Out1, Out2, Out3, Out4, Out5, Out6, ID: 1, and OnLine. The main area is divided into two sections:

- Routing Matrix:** A grid where input sources (InA and InB) are routed to outputs (Out1-6). Each input has buttons for GAIN, MUTE, HP/LP, PEQ, PHASE, and DELAY. Each output has buttons for XOVER, PEQ, GAIN, COMP, PHASE, DELAY, and MUTE. Colored lines (purple and yellow) show connections from InA and InB to various outputs.
- Output Routing View:** Six vertical panels, one for each output (Out1-6). Each panel contains two buttons: InA and InB. The InA button is green in Out1, Out3, and Out5, while the InB button is green in Out2, Out4, and Out6. Other buttons are grey.

Input PEQ

You can access the Input PEQ settings by clicking the Matrix tab (1) then selecting [PEQ] (2) for one of the inputs.

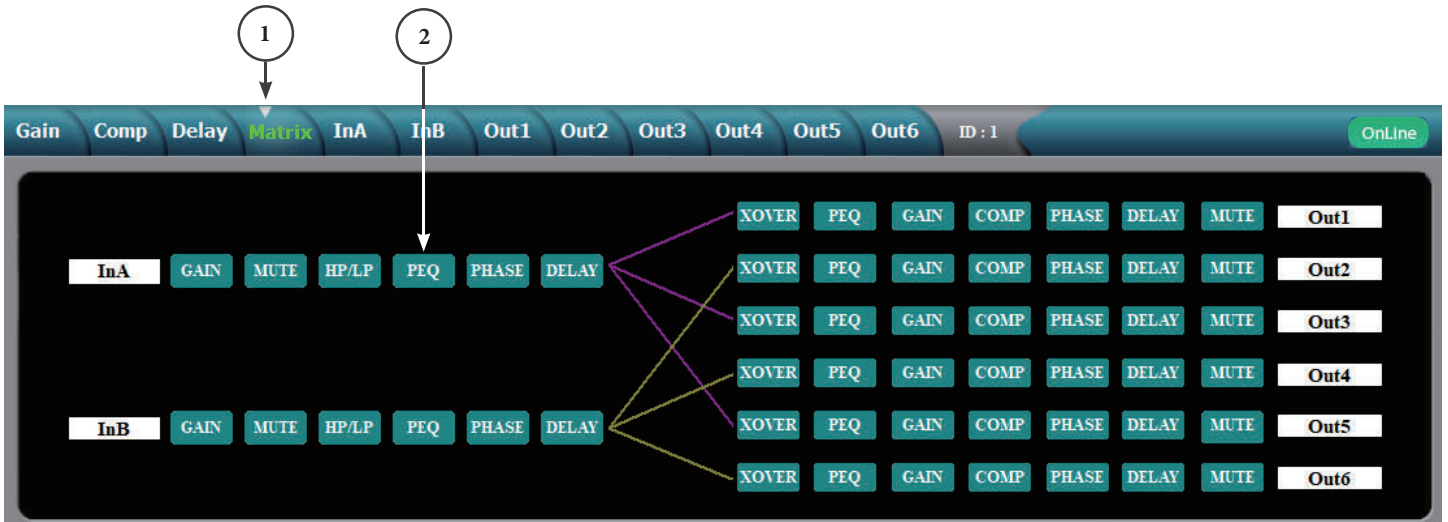

When you select a PEQ band # at the bottom left of the screen, the parameters for that band can be adjusted using the PEQ Parameter sliders. A PEQ band can also be adjusted by selecting the corresponding band on the graph with the mouse and dragging it to set frequency and amplitude. While holding the left mouse button down, the Q can be adjusted using the "+" and "-" keys. If you double click on a parameter in the PEQ matrix, you can directly type in a new value. The graph can display either the magnitude of filter responses or the resulting phase response. The graph of other inputs can also be overlaid on the screen by clicking the corresponding box on top of the graph.

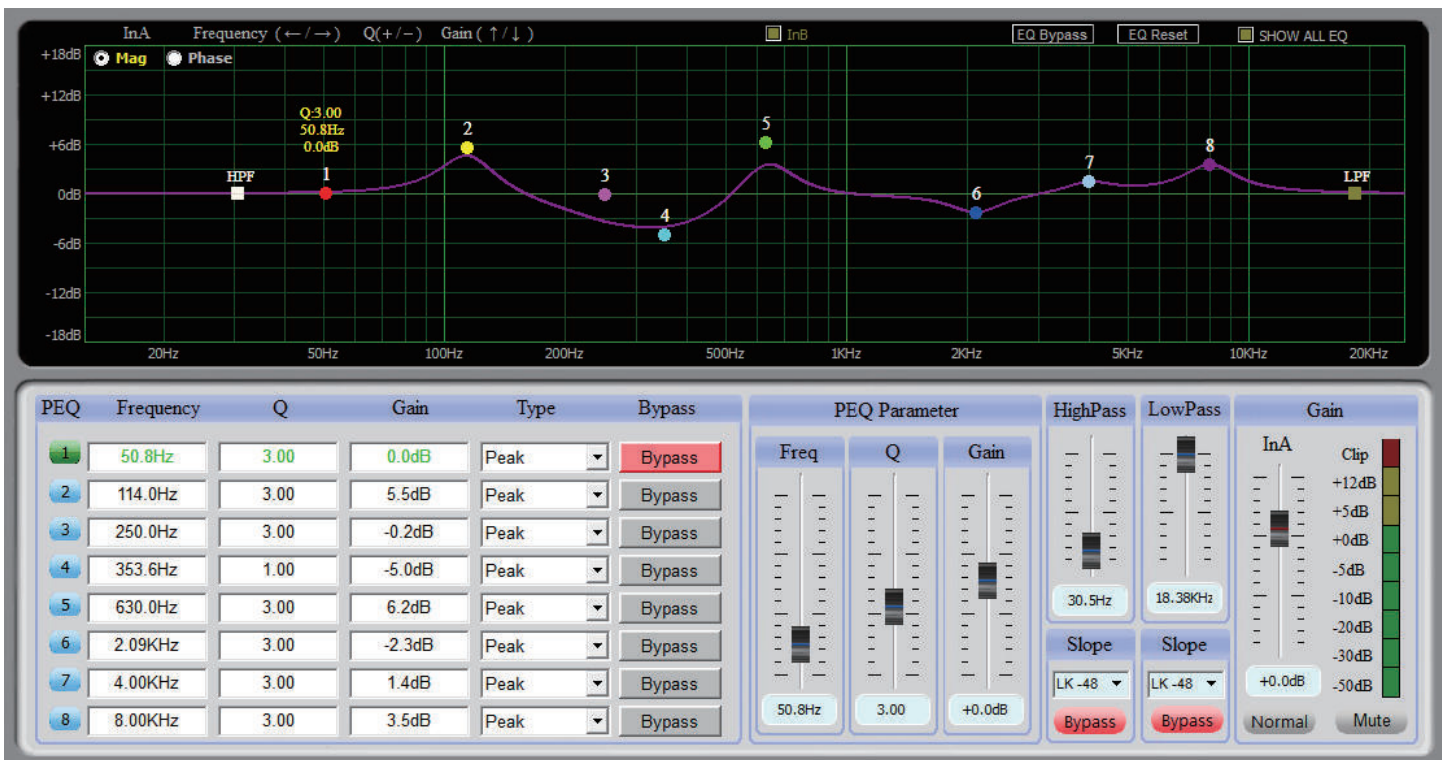

## Output PEQ

You can access the Output PEQ settings by clicking the Matrix tab (1) then selecting [PEQ] (2) for one of the outputs.

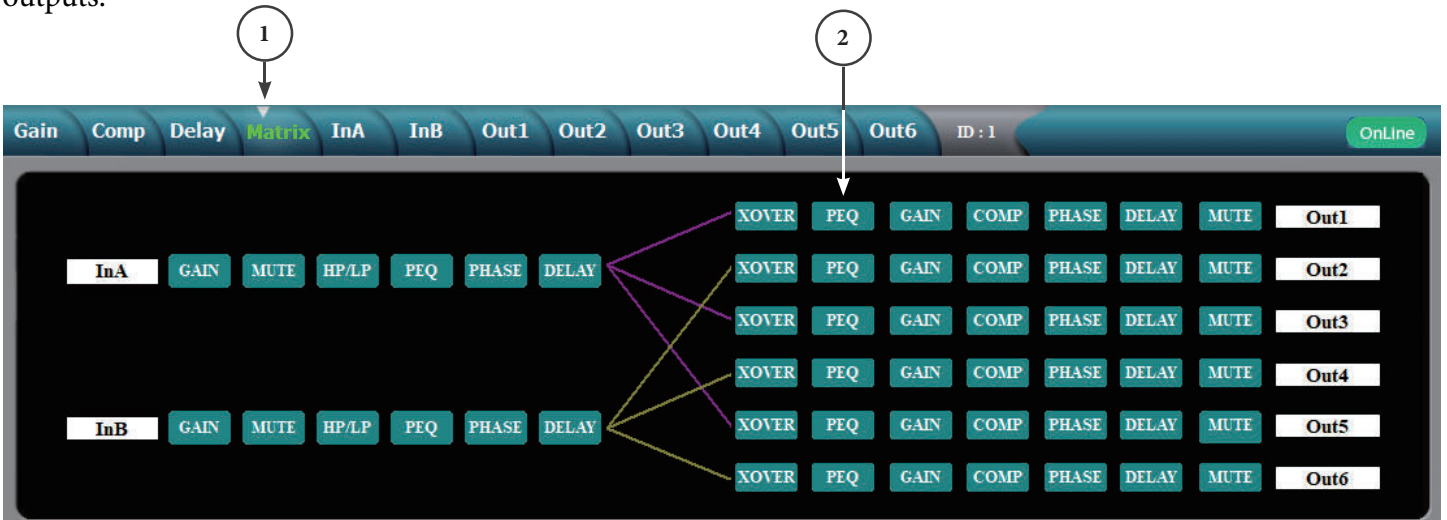

When you select a PEQ band # at the bottom left of the screen, the parameters for that band can be adjusted using the PEQ Parameter sliders. A PEQ band can also be adjusted by selecting the corresponding band on the graph with the mouse and dragging it to set frequency and amplitude. While holding the left mouse button down, the Q can be adjusted using the "+" and "-" keys. If you double click on a parameter in the PEQ matrix, you can directly type in a new value. The graph can display either the magnitude of filter responses or the resulting phase response. The graph of other outputs can also be overlaid on the screen by clicking the corresponding box on top of the graph.

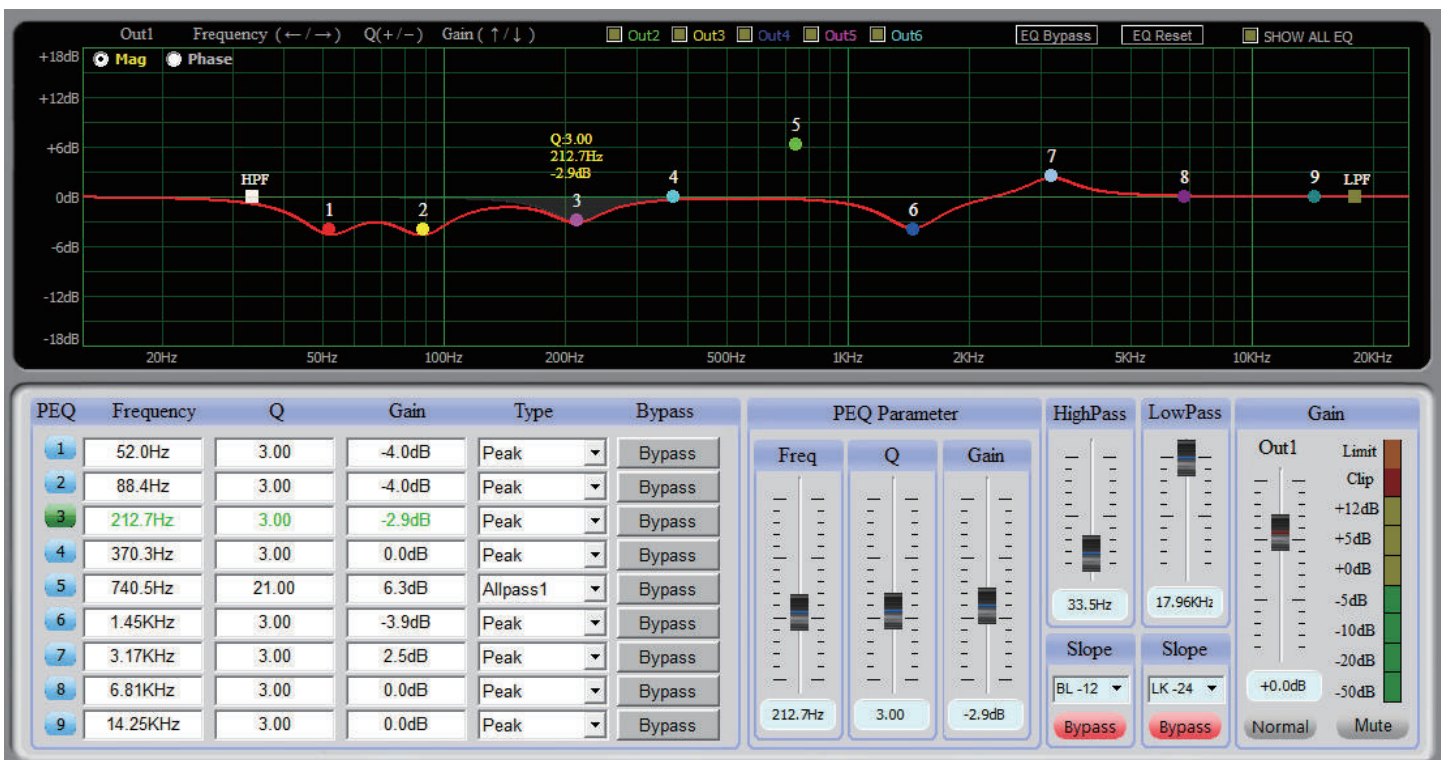

## File Management

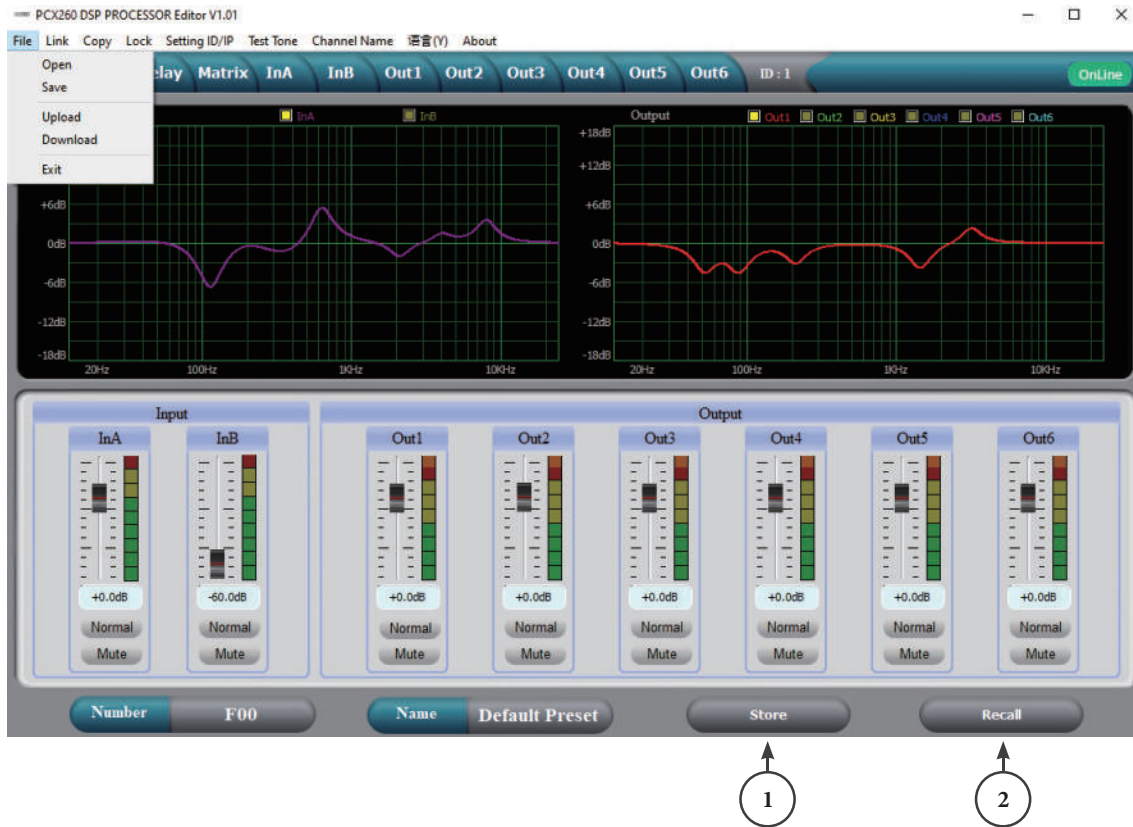

## Store (1)

The [Store] button at the bottom of the screen duplicates the Store button on the front panel of the PCX. The user can select one of 30 user storage locations to save the current settings.

## Recall (2)

The [Recall] button at the bottom of the screen duplicates the Recall button on the front panel of the PCX. The user can Recall one of 30 user stored presets.

## Menu &gt; File &gt; Open

Open a saved preset file (\*.prs). If you open a preset file and load it into the PCX, you must be connected and "Online". If the PCX is "Offline" it will load only into the Editor software. If you then connect the Editor to the PCX going "Online", the PCX settings will be loaded into the Editor overwriting the latest Editor settings.

## Menu &gt; File &gt; Save

Save the current settings in the PCX Editor software into a preset file.

## Menu &gt; File &gt; Upload

This uploads all of the presets from the PCX and saves them to a \*.unt unit file.

## Menu &gt; File &gt; Download

This loads a \*.unt file containing all of the unit presets into the connected unit. The PCX will be "Offline" when complete.

## RS-232 CONNECTION

Central control and connection to a Windows PC through the RS-232 port .

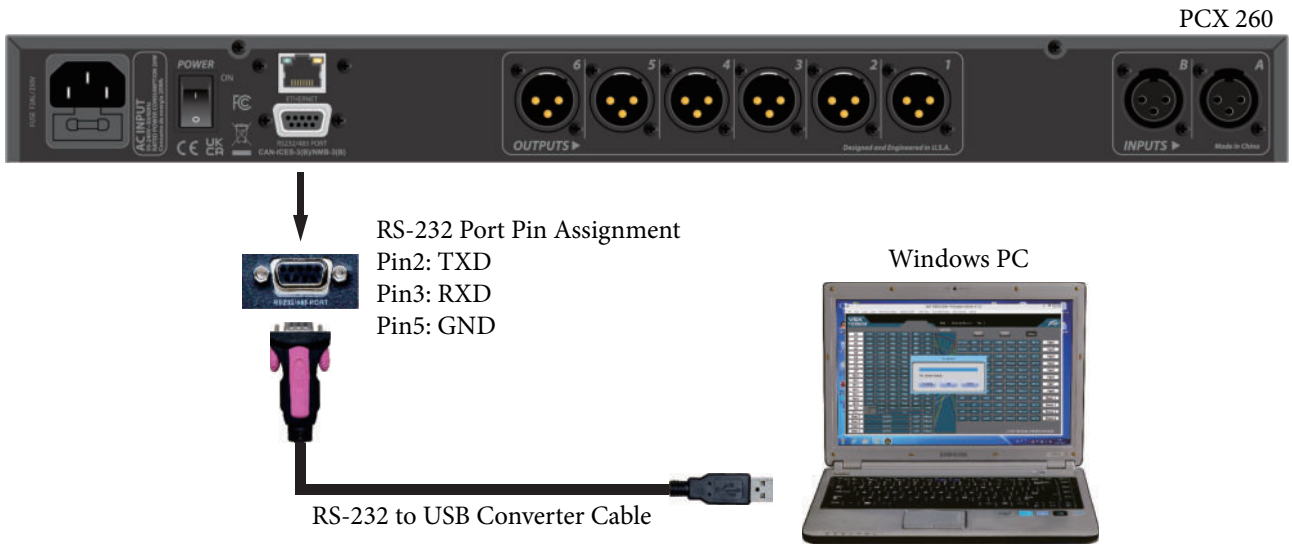

## RS-485 CONNECTION

RS-485 cascade control port. You can connect several devices by RS-485 link mode and set different IDs to control each unit separately.

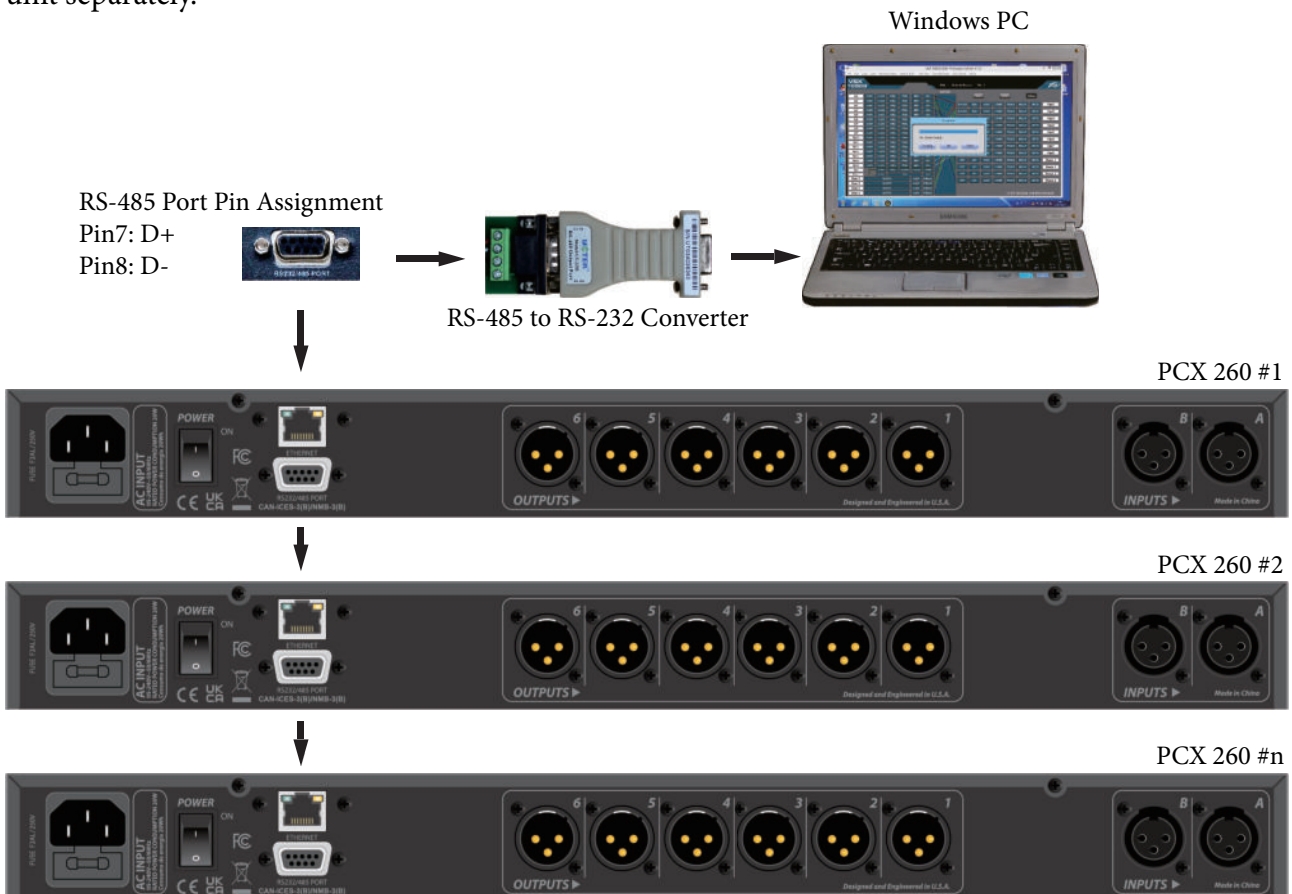

### 1. Control Package Format

	0	1	2	3	4	5	6	7	8
	DLE	STX	Device Address	CMD	Data1	Data2	Date3	STX	DLE
Packet	0x7B	0x7D	1~254	0X41~0X4A	0x??	0x??	0x??	0x7D	0x7B

### 2. Command Detail

#### (1) Gain Control (0x41)

	0	1	2	3	4	5	6	7	8
	DLE	STX	Device Address	CMD	In/Out	Channel	+/-	STX	DLE
Packet	0x7B	0x7D	1~254	0x41	In:0, Out:1	00~07	+:0,-:1	0x7D	0x7B

Example (InA Gain+): 7B7D0141000007D7B

#### (2) Mute Control (0x42)

	0	1	2	3	4	5	6	7	8
	DLE	STX	Device Address	CMD	In/Out	Channel	No/Yes	STX	DLE
Packet	0x7B	0x7D	1~254	0x42	In:0, Out:1	00~07	No:0, Yes:1	0x7D	0x7B

Example (Out1 Mute): 7B7D01420100007D7B

#### (3) Load Preset Control (0x43)

	0	1	2	3	4	5	6	7	8
	DLE	STX	Device Address	CMD	Factory/User	Preset	0x30	STX	DLE
Packet	0x7B	0x7D	1~254	0x43	F:0,U:1	0~30	0	0x7D	0x7B

Example (Recall user preset U01): 7B7D01330100007D7B

#### (4) Input Volume Control (0x44)

	0	1	2	3	4	5	6	7	8
	DLE	STX	Device Address	CMD	Channel	HI-VOL	LO-VOL	STX	DLE
Packet	0x7B	0x7D	1~254	0x44	00~07	0x??	0x??	0x7D	0x7B

Example (Set InA Volume +0.0dB): 7B7D01440001187D7B

**(5) Output Volume Control (0x45)**

	0	1	2	3	4	5	6	7	8
	DLE	STX	Device Address	CMD	Channel	HI-VOL	LO-VOL	STX	DLE
Packet	0x7B	0x7D	1~254	0x45	00~07	0x??	0x??	0x7D	0x7B

Example (Set Out2 Volume -3.0dB): 7B7D01450100FA7D7B

**(6) Get Now Gain (0x48)**

	0	1	2	3	4	5	6	7	8
	DLE	STX	Device Address	CMD	In/Out	Channel	0x30	STX	DLE
Packet	0x7B	0x7D	1~254	0x48	In:0, Out:1	0~7	0	0x7D	0x7B

MCU Return:        0-80 (-60~-20): 0.5dB/Step  
                       80-280 (-20~0): 0.1dB/Step  
                       280-400 (0~+12): 0.1dB/Step

Example (Read InA volume parameter): 7B7D01480000007D7B

**(7) Get Mute (0x49)**

	0	1	2	3	4	5	6	7	8
	DLE	STX	Device Address	CMD	In/Out	Channel	0x30	STX	DLE
Packet	0x7B	0x7D	1~254	0x49	In:0, Out:1	0~7	0	0x7D	0x7B

MCU Return: 0x00 or 0x01 = Un-Mute or Mute

Example (Read mute parameter): 7B7D01490000007D7B

**(8) Get Now Preset (0x4A)**

	0	1	2	3	4	5	6	7	8
	DLE	STX	Device Address	CMD	0x30	0x30	0x30	STX	DLE
Packet	0x7B	0x7D	1~254	0x4A	0	0	0	0x7D	0x7B

MCU Return: 0x00 ~ 0x31 = 0 : F00, 1-31: U01~U30

Example (Read now preset parameter): 7B7D014A00007D7B

Communication Parameters	Baud Rate	115200	Stop Bit	1
	Data Bit	8	Step	>=20ms
	Parity	None	ID	Default 1



The unit shall be a 1u rack-mountable digital audio matrix processor for loudspeaker management, capable of 2 input channels and 6 output channels, all independently assigned.

The unit shall operate at 96 kHz sample rate and 24-bit Delta-Sigma A/D and D/A conversion. The system latency from analogue input to output shall not exceed 3.5 ms.

All input channels shall provide the following processing: Gain, Mute, HP and LP filters, 8-band PEQ, Polarity and up to 680 ms of Delay. All outputs shall provide the following processing: 9-band PEQ, Gain, Compressor/Limiter, Polarity, up to 680 ms of Delay, and Mute.

All speaker processing outputs shall provide the following processing: Crossover & band-pass filters selectable between Butterworth, Bessel or Linkwitz-Riley each with alignments from 1<sup>st</sup> order (6 dB/Oct) to 8<sup>th</sup> order (48 dB/Oct). EQ filter types include PEQ, Low-Shelf, Hi-Shelf, Low Pass, High-Pass, All-Pass1 and All-Pass2.

The unit shall have 2 balanced XLR inputs and 6 balanced XLR outputs. All output channels shall be routable to any local output. An USB B port on the front panel and an RJ-45 Control Network port on the rear of the unit shall be provided for connection to a networked PC running the devices proprietary editor software.

The unit shall provide the facility to save presets. The presets shall be nameable and a descriptive text entry per preset provided.

The unit shall have an integrated power supply accepting AC mains voltages of 95 to 240 VAC, 50/60 Hz, 15W max via an earthed 3-pin IEC male connector mounted on the rear chassis. The unit shall be no more than 1.75 inches (45 mm) high by 19 inches (483 mm) wide by 8.25 inches (205 mm) deep weighing no more than 5.28 pounds (2.4 kg).

The digital audio matrix processor shall be the Crest Audio PCX™ 260.

**Configuration:** 2 Inputs & 6 Outputs

**Input Impedance:** 20 k Ohms

**Output Impedance:** 100 Ohms

**Frequency Response Input to Output:**

**+0 / -0.5 dB:** 10 Hz - 21 kHz

**+0 / -1.0 dB:** 10 Hz - 32 kHz

**Maximum Input Level:** +20 dBU

**Maximum Output Level:** +20 dBU

**THD +N @ 1 kHz:** 0.007%

**Noise Floor (22 Hz - 22 kHz):** -87 dBU (unweighted) & -89 dB (A-weighted)

**Dynamic Range:** >107 dB (unweighted) & >109 dB (A-weighted)

**Crosstalk between Channels:** <-100 dB @ 1 kHz

**Latency (analog Input to analog Output):** 3.5 ms

**Sample Rate:** 96 kHz

**Delta-Sigma A/D & D/A Converters:** 24-bit

**Inputs:** 2 x XLR female balanced

**Outputs:** 6 x XLR male balanced

**Ethernet Interface:** RJ-45 / 10 Mbps / Static IPv4 address

**USB Interface:** USB "B"

**RS-232 & RS-485:** D-Sub 9

**Baud Rate:** 115200

**Data Bits:** 8

**Parity:** None

**Stop Bits:** 1

**RS-232 Pin Out:** Pin 2 - RX | Pin 3 - TX | Pin 5 - GND

**RS-485 Pin Out:** Pin 7 - D+ | Pin 8 - D-

**AC Power Input Voltage:** 95 to 240 VAC 50/60 Hz

**Fuse:** F2AL 250V (5x20 mm)

**Power Consumption:** 15 Watts

**Overall Dimensions (HWD):**

1.75" x 19" x 8.25" (45 x 483 x 205 mm)

**Net Weight:** 5.28 lbs (2.4 kg)







[www.crestaudio.com](http://www.crestaudio.com)



Features and specifications subject to change without notice.

Crest Audio 5022 HWY 493 N. Meridian, MS 39305 (601) 483-5365 FAX (601) 486-1278



Logo referenced in Directive 2002/96/EC Annex IV  
(OJ(L)37/38,13.02.03 and defined in EN 50419: 2005  
The bar is the symbol for marking of new waste and  
is applied only to equipment manufactured after  
13 August 2005